

ACE

PORTABLE HYDRAULIC POWER UNIT

**Diesel Engine Driven
Model HSP-F4L**

**HYDRAULIC SPECIFICATIONS**

Hose Ports: 1" N.P.T.

Hydraulic Pump: Pressure Compensated Piston Type

Hydraulic Output: Variable, Max 28 GPM [121 LPM]

Operating Pressure: Max. 2900 PSI [200 Bar];

3000 PSI [206 Bar] Bypass

Hydraulic Oil: 214-320 S.S.U. @ 100°F (64°C)

Hydraulic Oil Reservoir Capacity: 45 U.S. Gallons [189 L]

Standard Equipment:

Lifting Bail

Skid Base

Pressure Control Valve

System Relief Valve

Spin on Return Filter W/Indicator

Fluid Level/Temperature Gauge

Tank Top Filler/ Strainer

Variable Speed Control

Liquid Filled Pressure Gauge

Optional Equipment:

Battery

2 Wheel Truck Assy with P235/75R15 Pneumatic Tires

Over-the-Road Trailer (Meets D.O.T. Requirements)

*1.00" [25,4 mm] Hydraulic Hoses with Quick

Disconnect Fittings

**55 Gal. (208 L) Mobile EAL 224H Vegetable-Based Hydraulic Oil

* Hydraulic Hose Available in 50 Foot [15,2 Meter] Increments;
Maximum Recommended Length 150 Feet [45,7 Meters]
Specify Length at Time of Order

** Recommended for Use in Environmentally Sensitive Areas.

ENGINE SPECIFICATIONS

Model: Deutz F4L912

Type: Four Cylinder, Four Cycle,
Air Cooled Diesel Engine

Displacement: 230.1 Cu. In. [3.8 L]

Governor: Mechanical

Lubrication: Forced Circulation

Air Cleaner: Oil Bath

Oil Reservoir: 11.6 U.S. Qts [11.0 L] Dry

10.0 U.S. Qts [9.5 L] Refill

Fuel Tank: 38.9 U.S. Gallons [147.2 L]

Operating Time; Full Load: 17.5 Hours

Starter: 12 Volt Electric

Standard Features:

Safety Shut Down Switches for:

Low Oil Pressure

V-Belt Failure

High Hydraulic Oil Temp.

Instrument Panel with:

Temp. Gauge, Oil pressure Gauge

Ammeter, Hourmeter, Tachometer

Alternator Failure Light

Muffler with Guard and Weather Cap

Engine Mounted Oil Cooler

DEUTZ PUBLISHED PERFORMANCE:

Max. Cont. B.H.P. 63 @ 2300 RPM

Max. Dyn. B.H.P. 80 @ 2800 RPM



THE GORMAN-RUPP COMPANY • MANSFIELD, OHIO

GORMAN-RUPP OF CANADA LIMITED • ST. THOMAS, ONTARIO, CANADA

Printed in U.S.A.

Specification Data

SECTION 140, PAGE 1600

**OVERALL DIMENSIONS
and
WEIGHTS APPROXIMATE**

	SKID BASE	2-WHEEL
NET WEIGHT (Dry):	1900 LBS. [862 KG.]	2200 LBS. [998 KG.]
SHIPPING WEIGHT:	2000 LBS. [907 KG.]	2200 LBS. [998 KG.]
EXPORT CRATE SIZE:	131 CU. FT. [3.7 CU. M.]	149 CU. FT. [4.2 CU. M.]

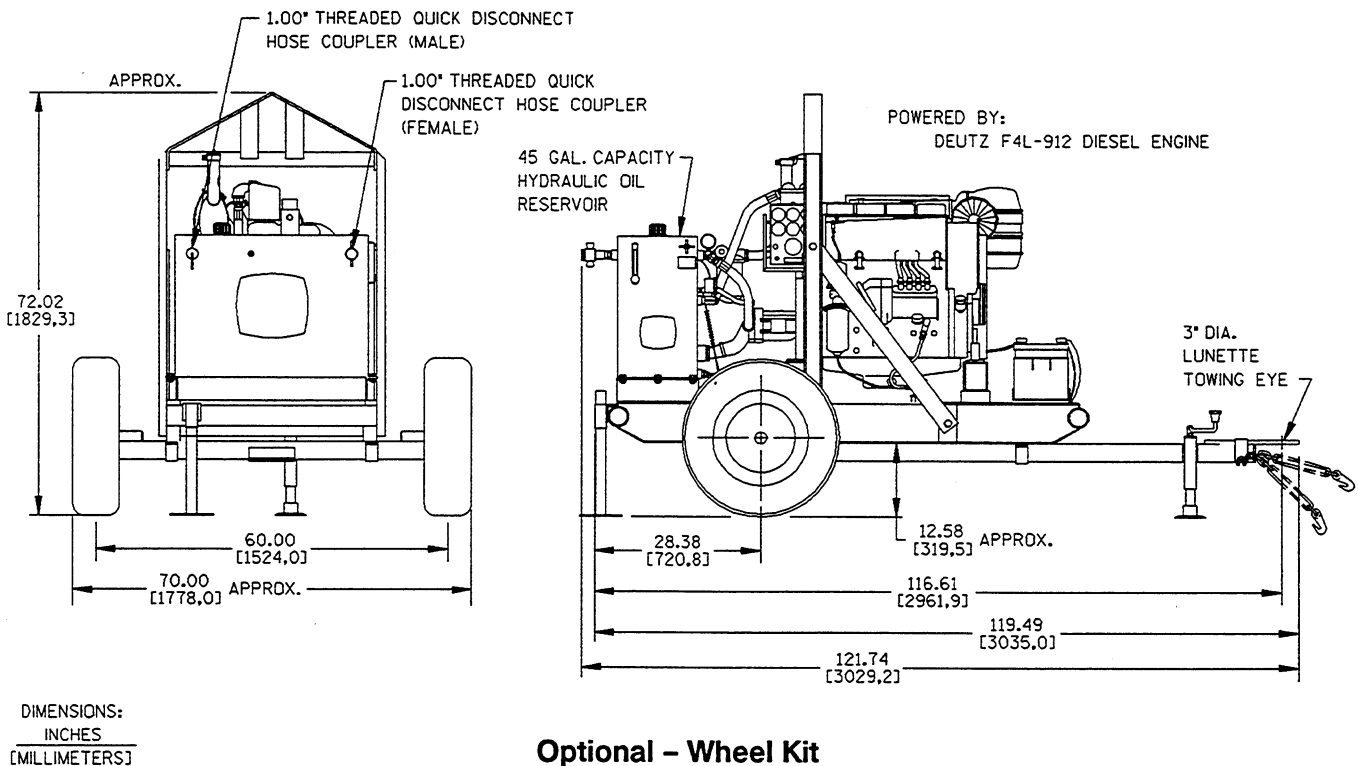
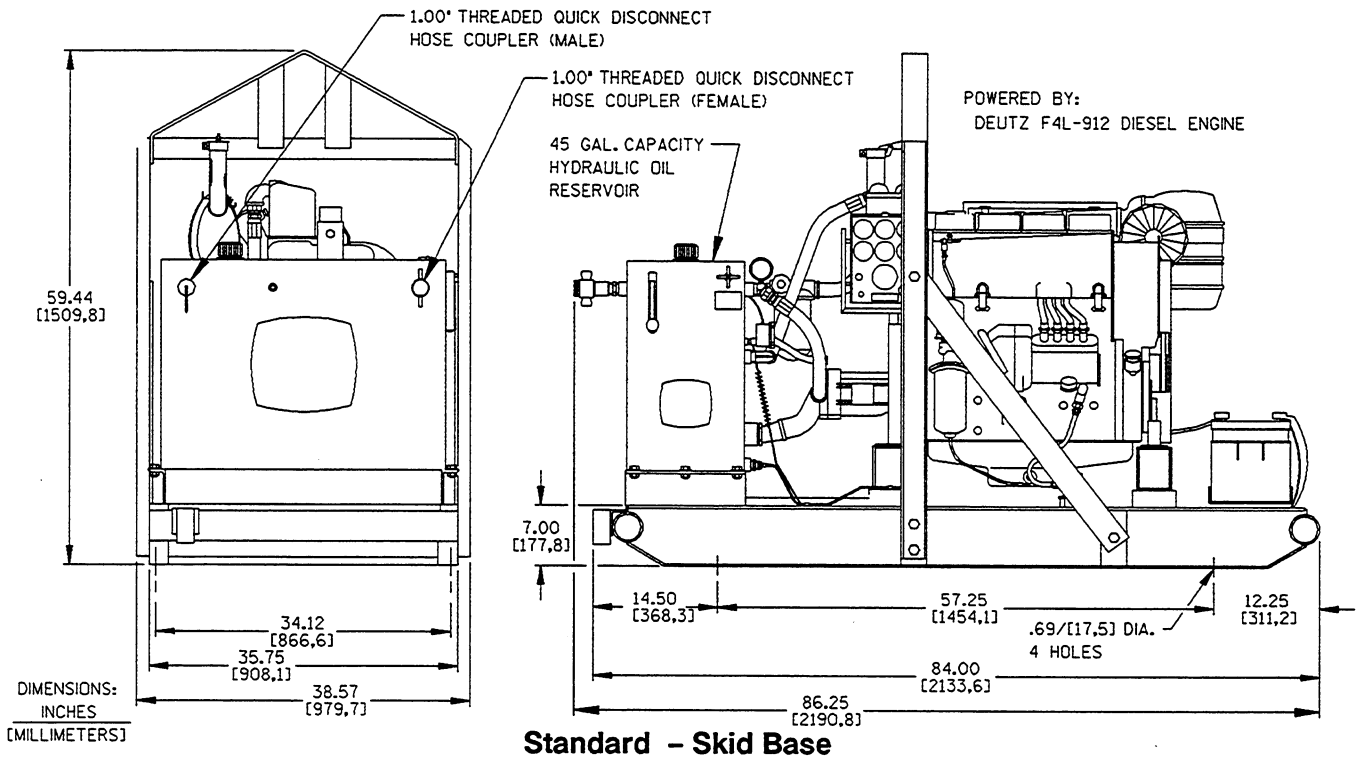

THE GORMAN-RUPP COMPANY • MANSFIELD, OHIO

GORMAN-RUPP OF CANADA LIMITED • ST. THOMAS, ONTARIO, CANADA

Printed in U.S.A.